

TVW DF10 04 AD1 Engineering Specification

1. Scope

TVW DF10 04 AD1 is TVS arrays designed to protect high-speed signal lines from overvoltage hazard of Electrostatic Discharge (**ESD**) and Electrical Fast Transients (**EFT**). These interfaces can be used in **HDMI**, **DisplayPort** interface, **SATA** and **eSATA** interface, digital visual interface (DVI), USB2.0, IEEE 1394 Firewire Ports, Ethernet port (10/100/1000 Mb/s), etc.

TVW DF10 04 AD1 incorporates a pair of rail-to-rail diodes with ultra low capacitance for each of four I/O channels. Additional Zener diode is employed to minimize the influence of supply voltage. The ESD protection of TVS arrays meets the immunity standard of IEC 61000-4-2, level 4 ($\pm 15\text{kV}$ air, $\pm 8\text{kV}$ contact discharge).

TVW DF10 04 AD1's are **lead free** and in **ROHS** compliance.

2. Explanation of Part Number

<u>TV</u>	<u>W</u>	<u>DF10</u>	<u>04</u>	<u>AD1</u>
(1)	(2)	(3)	(4)	(5)

- (1) Product Type : TV=TVS Diode
- (2) Capacitance Code : W=Ultra Low Capacitance
- (3) Package Size Code
- (4) Channel Code : 04=4 Channels
- (5) Specialized Specification Code

3. Circuit Diagram /Pin Configuration

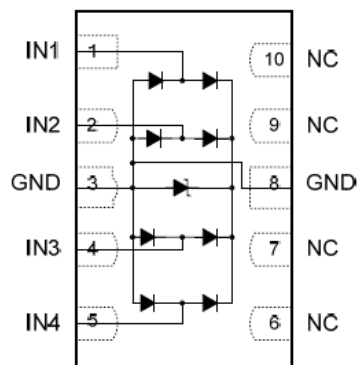

**Circuit Diagram
DFN-10 (Top-view)**

4. Specifications

4.1. ABSOLUTE MAXIMUM RATINGS

Parameter	Symbol	Typical	Unit
Peak Pulse Power ($t_p = 8/20 \mu s$)	Ppk	150	W
Maximum Peak Pulse Current ($t_p = 8/20 \mu s$)	Ipp	5	A
ESD per IEC 61000 – 4 – 2 (Air)	Vpp	± 15	KV
ESD per IEC 61000 – 4 – 2 (Contact)	Vpp	± 12	KV
Operating Junction Temperature	T _J	-55 ~ 125	°C
Storage Temperature Range	T _{STG}	-55 ~ 150	°C
Lead Soldering Temperature	T _L	260 (10sec)	°C

4.2. ELECTRICAL CHARACTERISTICS

Parameter	Symbol	Conditions	Min.	Typ	Max.	Unit
Reverse Stand – Off Voltage	V _{RWM}				3.3	V
Forward Voltage @ I _F	V _F	I _F = 10mA			1.3	V
Reverse Breakdown Voltage	V _{BR}	I _t = 1mA	5.6	6.4	7	V
Reverse Leakage Current	I _R	V _{RWM} = 5V , T=25°C		0.5	1	μA
Forward Clamping Voltage	V _{C1}	I _{pp} = 1A , t _p = 8/20 μs		1.8		V
Reverse Clamping Voltage	V _{C2}	I _{pp} = 1A , t _p = 8/20 μs		6.2	10	V
Junction Capacitance	C _j	V _R = 0V, f = 1MHz Any I/O pin to Ground		0.5	0.6	pF
		V _R = 0V, f = 1MHz Between I/O pins		0.25	0.3	

4.3. TYPICAL CHARACTERISTICS

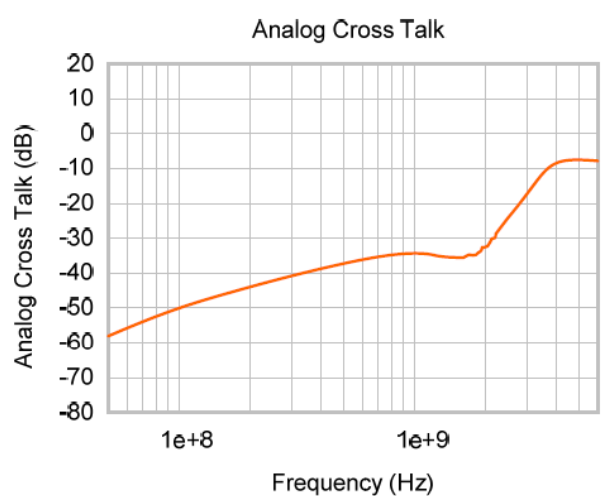
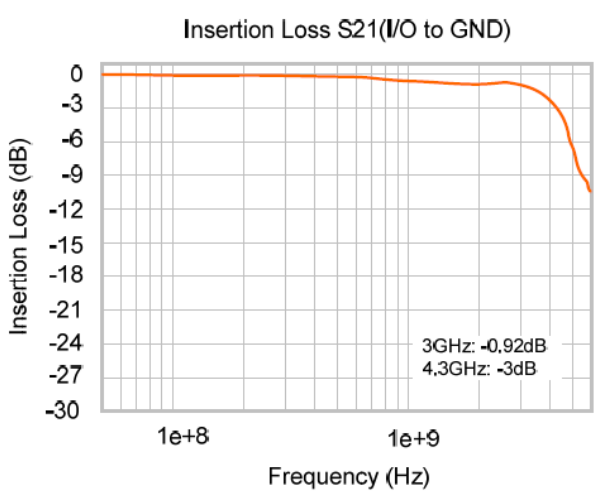
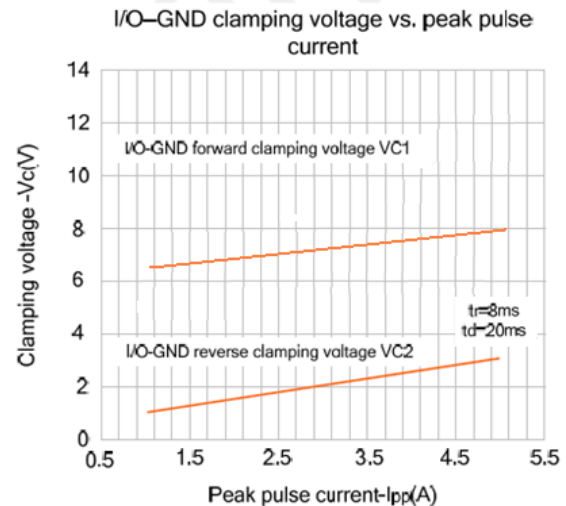
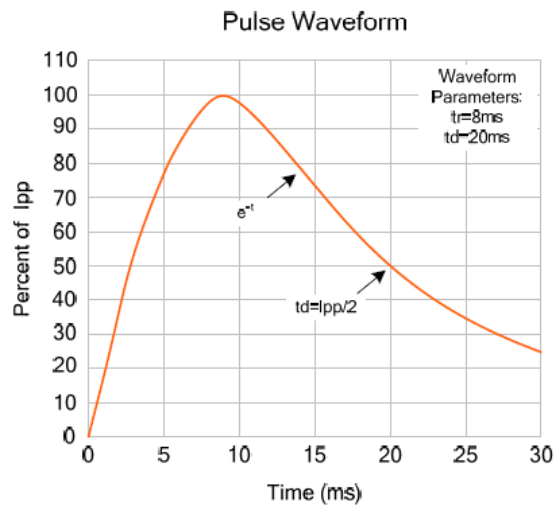
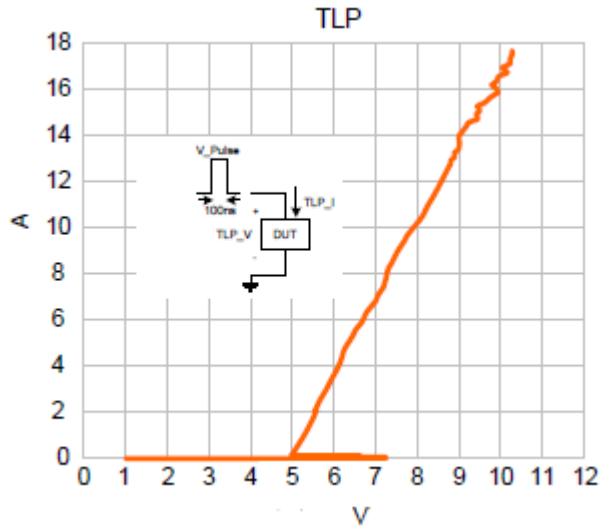
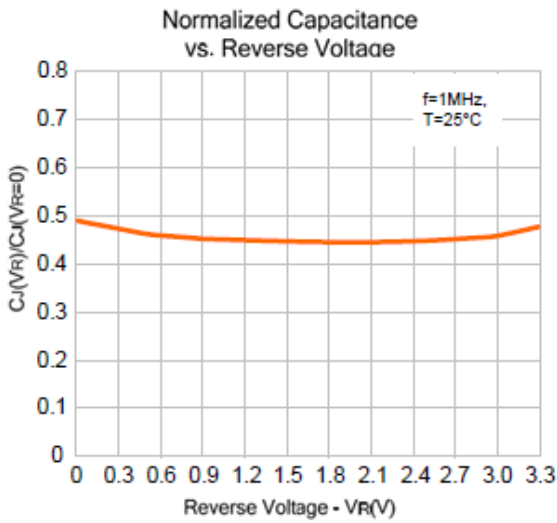

5. LAND LAYOUT

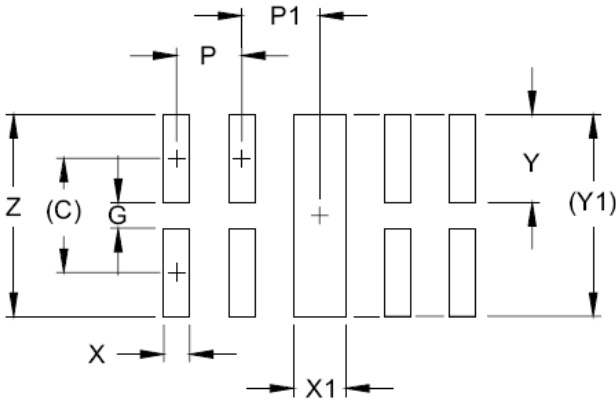

DIMENSIONS		
DIM	INCHES	MILLIMETERS
C	(.034)	(0.875)
G	.008	0.20
P	.020	0.50
P1	.020	0.50
X	.008	0.20
X1	.016	0.40
Y	.027	0.675
Y1	(.061)	(1.55)
Z	.061	1.55

NOTES:

1. CONTROLLING DIMENSIONS ARE IN MILLIMETERS (ANGLES IN DEGREES).
2. THIS LAND PATTERN IS FOR REFERENCE PURPOSES ONLY. CONSULT YOUR MANUFACTURING GROUP TO ENSURE YOUR COMPANY'S MANUFACTURING GUIDELINES ARE MET.

6. IC POSITION IN THE TAPE

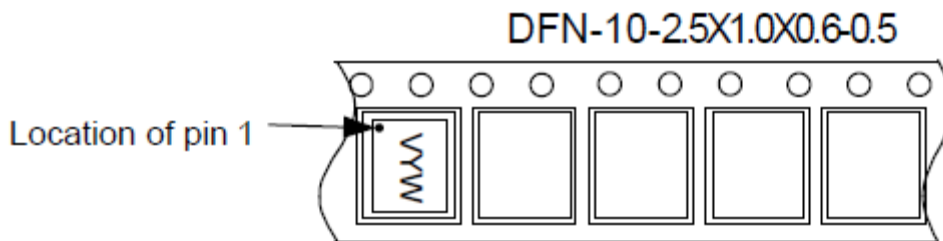

7. Application information

HDMI Port Application

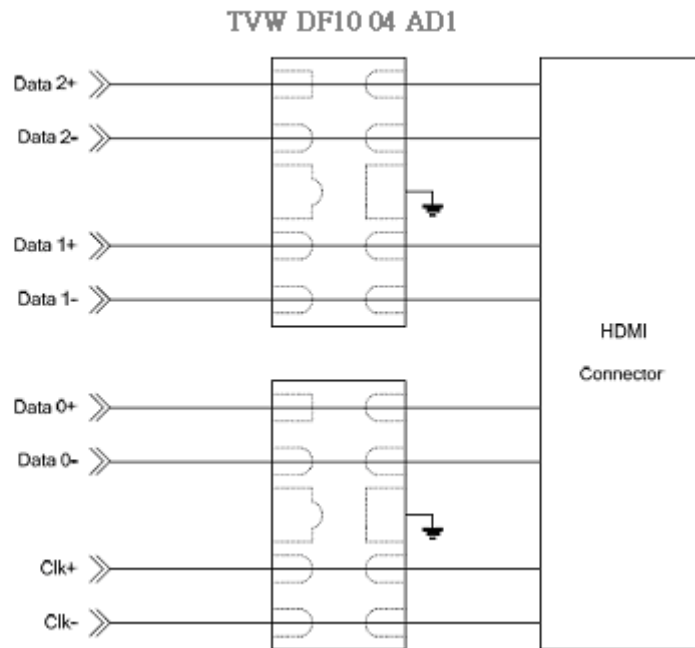

Display Port Application

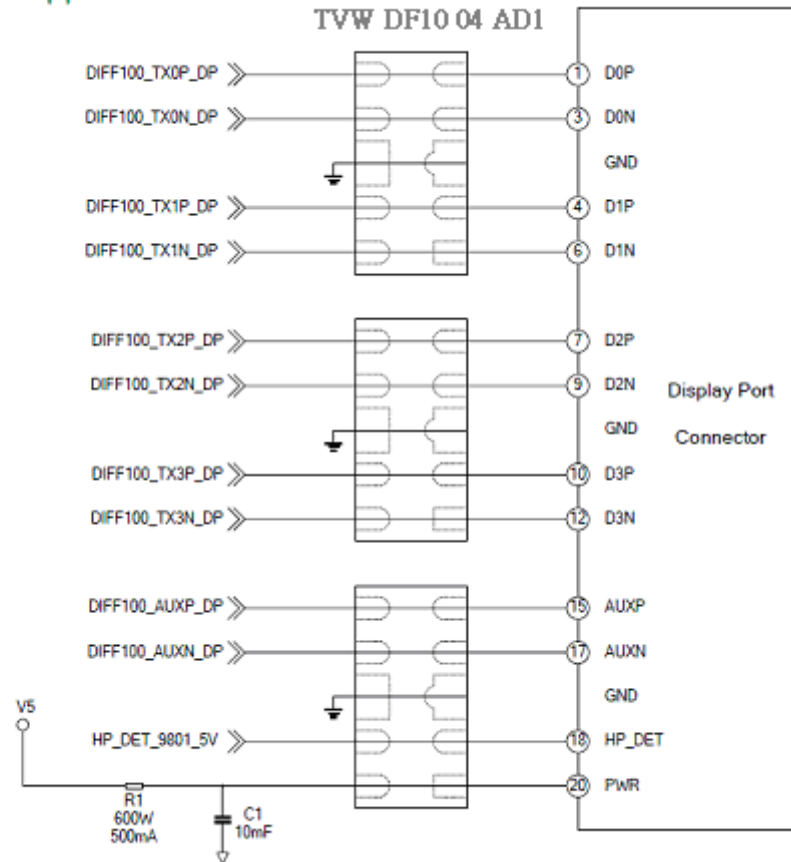

8. MARKING CODE

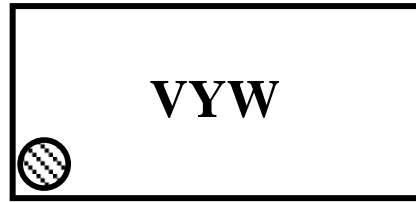

V=Device Code
YW=Data code

9. Mechanical Details

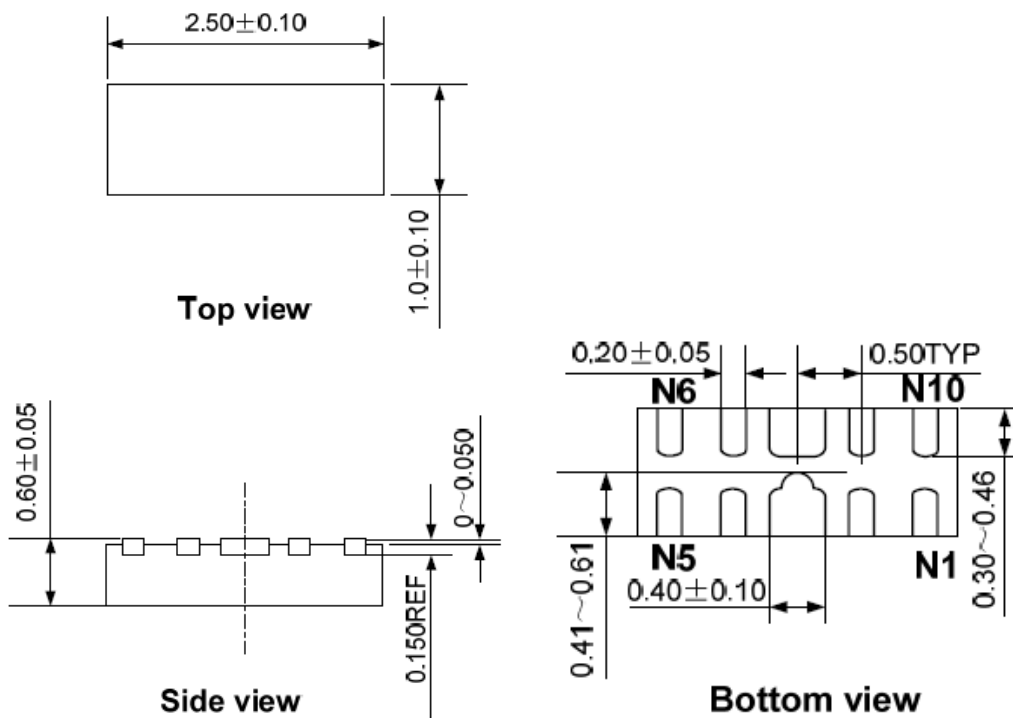

9.1. Taping Quantity:

3,000pcs/ Reel (for 7" Reel)